

GLA-215P-MB-VB - Glasgow 5LT Halogen Pendant MB & VB w/ Champagne Glass

5 Light Pendant, Matte Black / Vintage Bronze Finish, Champagne Glass

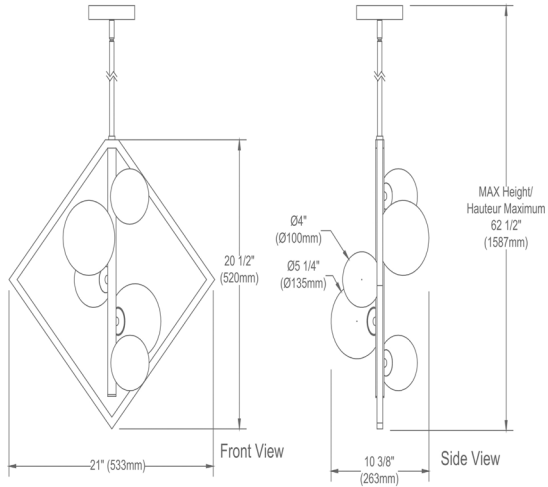

Height	20.5"
Width/Length	21"
Depth	10.5"
Weight	7 lbs

Body Material	Metal
Finish/Color	Vintage Bronze
Type of Finish	Electroplated

Light Qty	5
Light Base	G9
Light Max Watt	25
Light Inc	No

Dimmable	Dimmable
LED Compatible	LED Compatible
Total Wattage	125W

Second Material	Glass
Second Finish/Color	Champagne
Second Type of Finish	Glass

Rated For	Dry Location
Voltage	120V

Approval	cUL or equivalent
Warranty	1 Year Limited
Install Position	Ceiling

Extension Length	39 (8+11+20)
-------------------------	--------------

Date:	Notes:
Fixture Type:	
Job Name:	

Lighting | LED | Shades | Custom Designs

www.dainolite.com 1-888-564-1262 dainolite@dainolite.com

